

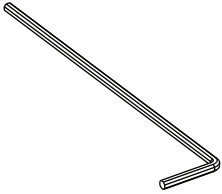

We recommend using a powered screwdriver for assembly, but to also to fix the wall anchor. This fixes the taller units to the back wall to prevent any tipping accidents. We provide 2 x hex keys to fit all the bolts, but also supply a 3mm hex tip, screwdriver ph2 tip and an 8mm masonry drill bit for using with an electric screwdriver. Otherwise you'll need a manual screwdriver with PH2 tip.

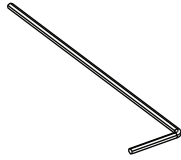

HEX KEY 3MM
FOR SIDE PANELS



HEX KEY 2.5MM
FOR FLAP STAY



HEX KEY TIP 3MM
FOR ELECTRIC DRIVER
FOR SIDE PANEL BOLTS



PH2 DRIVE TIP FOR
SELF DRILLING SCREWS
& BACK PANELS



FOOT x 4
FOR SIDE PANEL
BASE

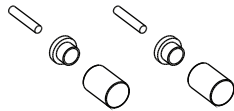

2 X SOCKET SCREWS +
NYLON WASHER
+ HINGE CAP



SELF DRILLING
SCREWS FOR
BACK PANELS



M5 BOLTS
TO CONNECT
SIDE PANELS

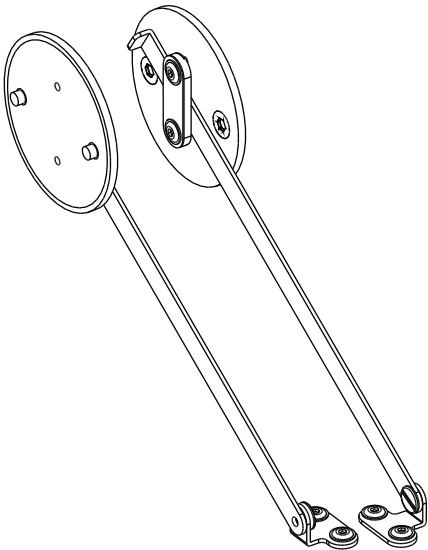

DOOR FLAP STAY x 2
WITH BOLTS, USE BOTH
HEX KEYS

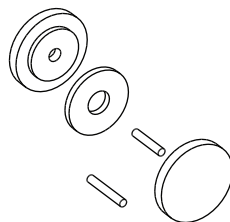

JOIN CONNECTOR +
SOCKET SCREWS FOR
SINGLE OR DOUBLE UNIT

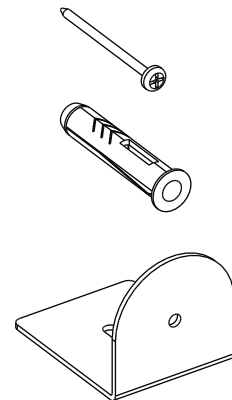

WALL ANCHOR x 1
WITH WALL PLUG,
8MM MASONRY DRILL
BIT AND SCREW

All our JOIN units are assembled the same way. This guide shows the largest being assembled, all the parts are bolted or screwed together. We would recommend using two people to assemble and lift the largest units T4 & T5 up from the floor assembly position.

FRONT VIEW

REAR VIEW

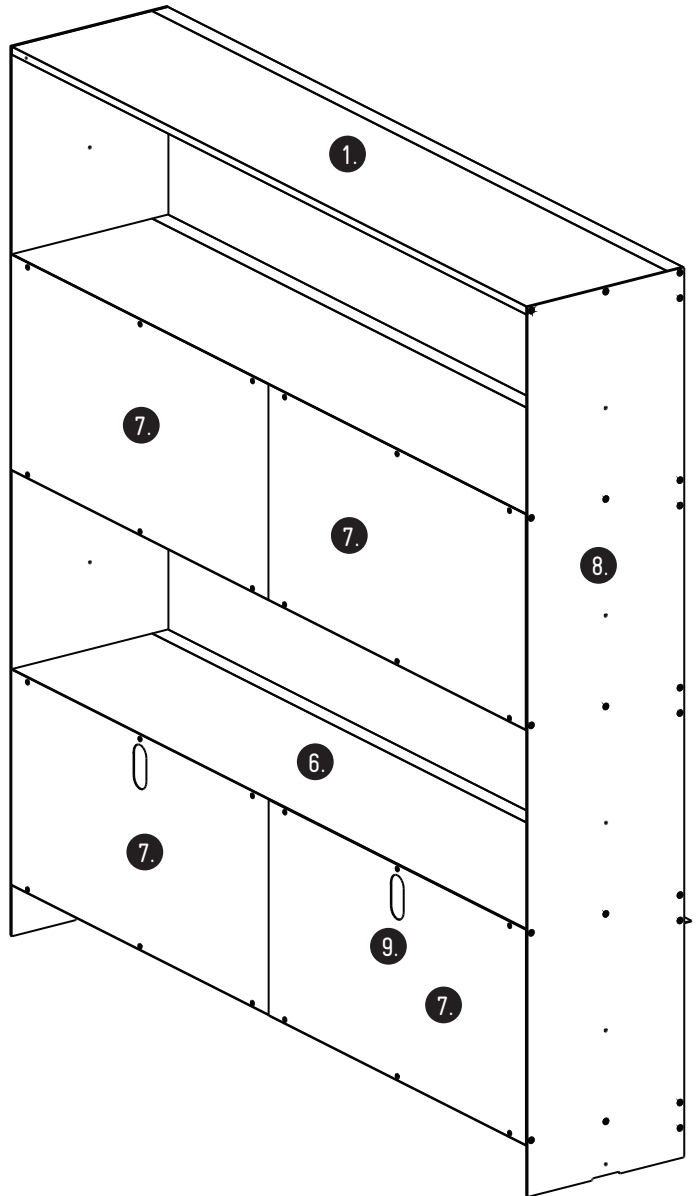
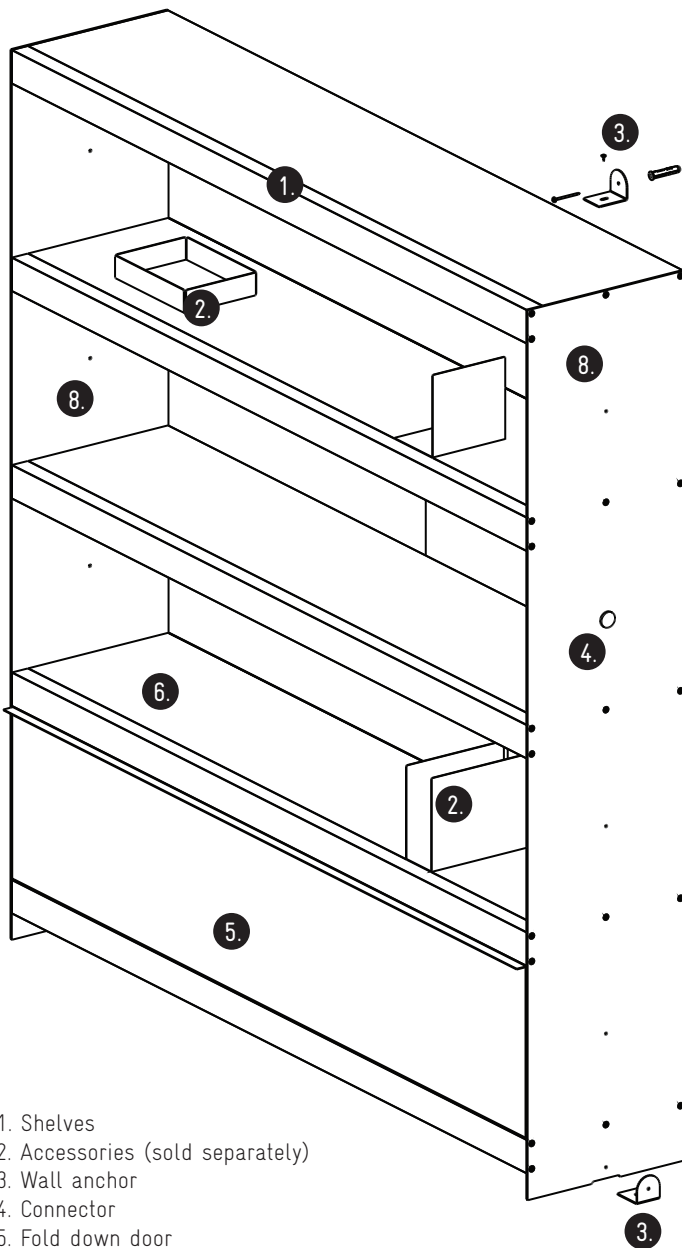

- 1. Shelves
- 2. Accessories (sold separately)
- 3. Wall anchor
- 4. Connector
- 5. Fold down door
- 6. Shelf with closing strip/tab
- 7. Back panels
- 8. Side panels
- 9. Cable opening

All our JOIN units are assembled the same way. This guide shows the largest being assembled. Contact us if you need more help, we are always happy to help, you can contact us on (0)1727 834034 or email studio@madebyonandon.com.

1.

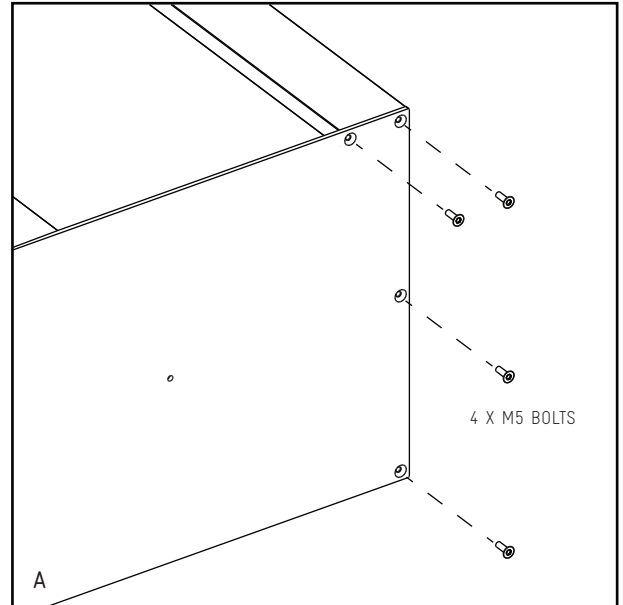
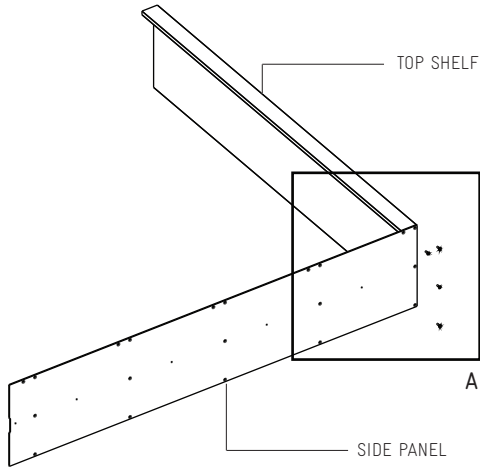

Cover the floor area with a soft surface (blanket or rug). Assemble the unit on the floor facing up so the parts are on their back. Connect the side panel to the top shelf using the M5 bolts and the 3mm hex key as shown.

2.

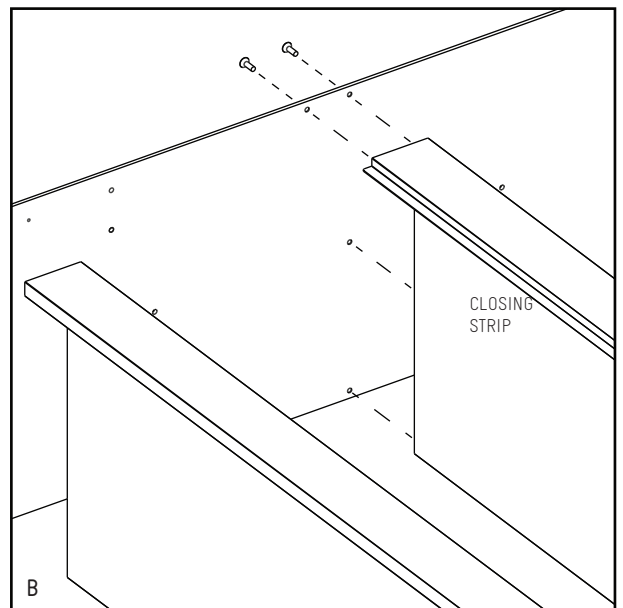
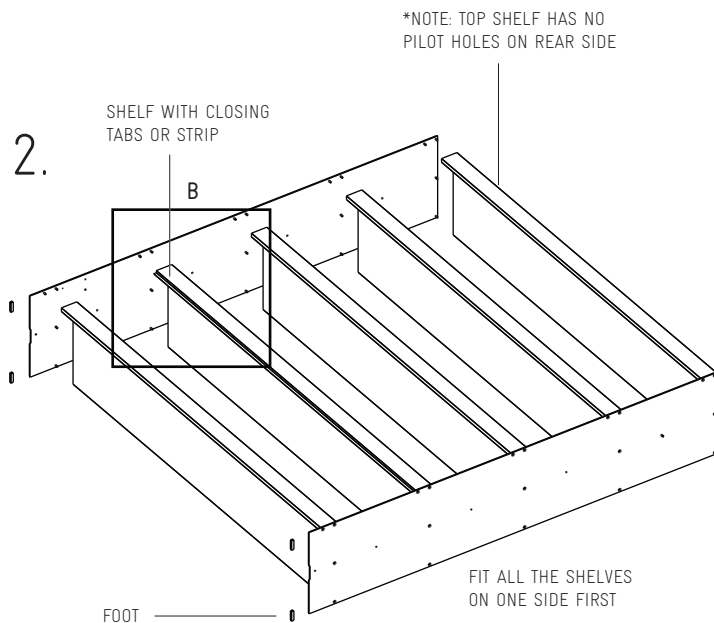

Connect all the shelves to the first side panel before connecting the other side, but fit the shelf with the closing strip two shelves up from the bottom. When both side panels are connected slide or push on the four feet.

Fold down doors are fitted to the bottom of the module by connecting two hinges and two flap stays. Magnets in the top of the door locate with the closing strip or tabs above to keep the door shut. The friction flap stay can be adjusted to control the door's movement and speed of opening.

3.

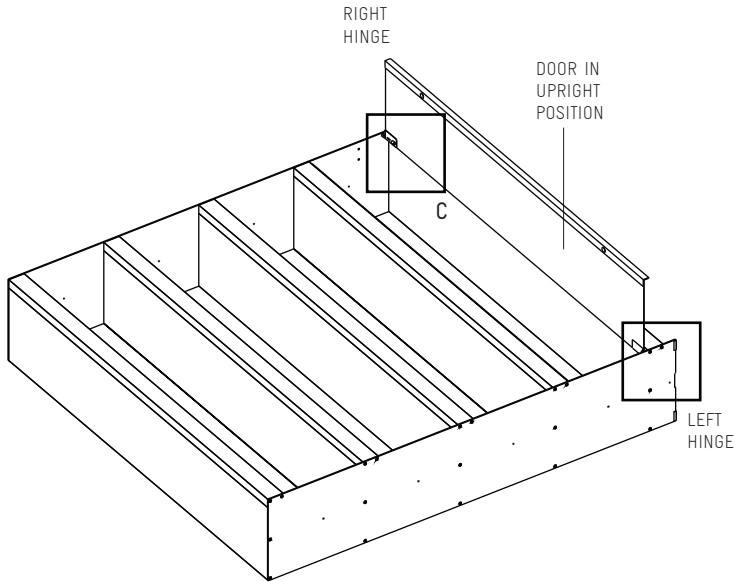

FIT THE HINGE

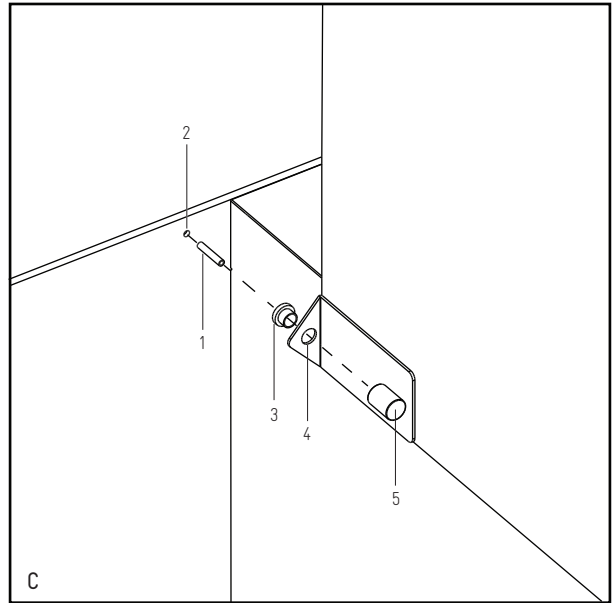

Screw in the socket screw (1) into the side panel hole (2) tighten using the 2.5mm hex key, don't overtighten. Insert the shoulder washer (3) into the pivot hinge hole (4) on both sides of the door. Slide one side of the door onto the socket screw. Hold the door and align the other side, hinge hole and side panel hole and locate the 2nd socket screw through both and screw into the side panel. Tighten with the hex key. Attach the hinge caps (5) to cover the socket screws.

4.

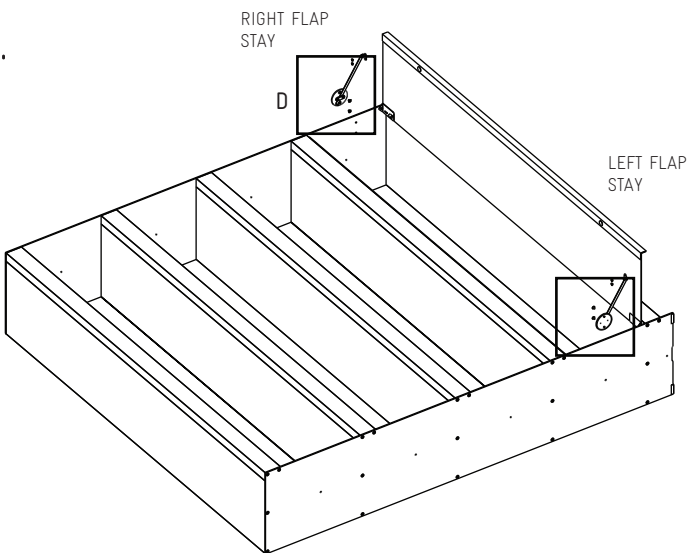

FIT THE FLAP STAYS

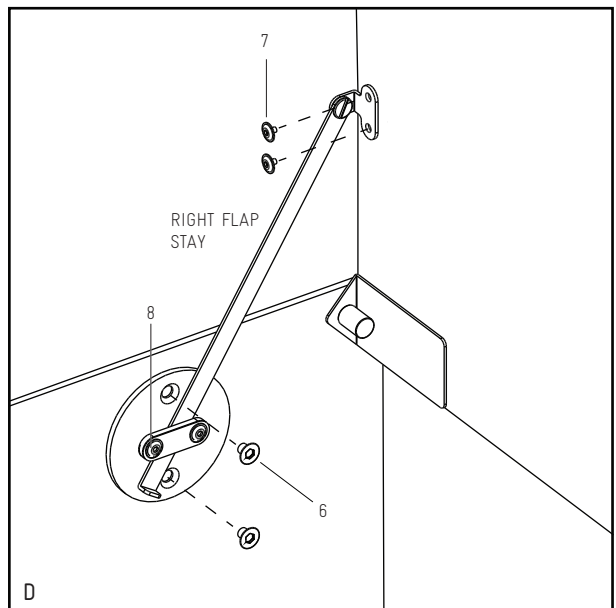

Bolt the right flap stay to the right side panel (6) using the countersunk bolts. Next bolt the flap stay arm to the door using the M4 bolts (7) with the 2.5mm hex key. When completed repeat both steps for the left flap stay. The bolts (8) can be adjusted with small quarter turns to increase or decrease the friction and control the door movement.

We would recommend two people lift the largest units T4 & T5 into the upright position. Protect the bottom corners when raising the unit into position. Check your door is working and fitted correctly and then fit your back panels.

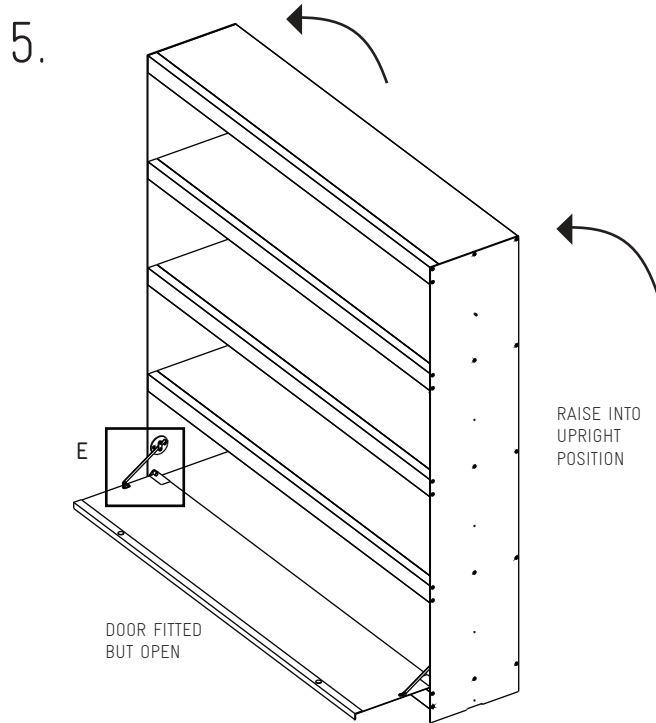

FLAP STAYS FINISHED

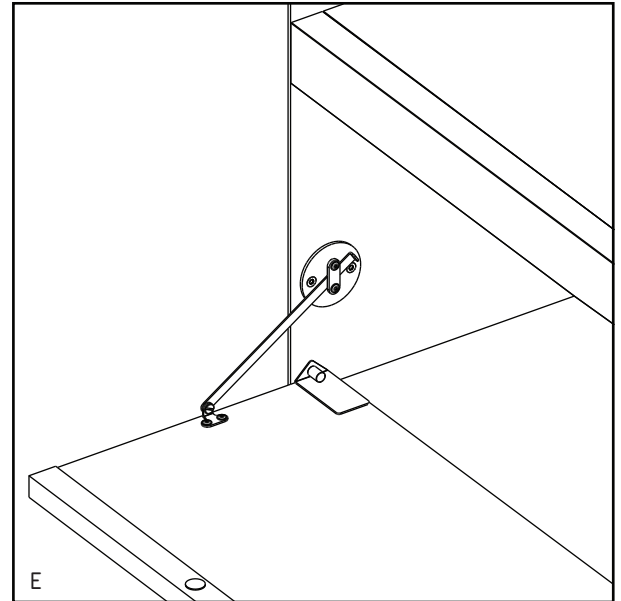

Your door parts should look like this when the unit is in its upright position.

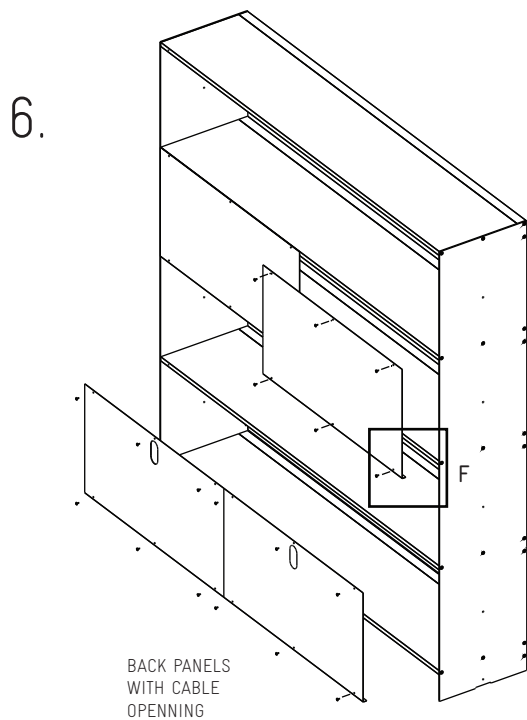

FIT PANELS TO REAR

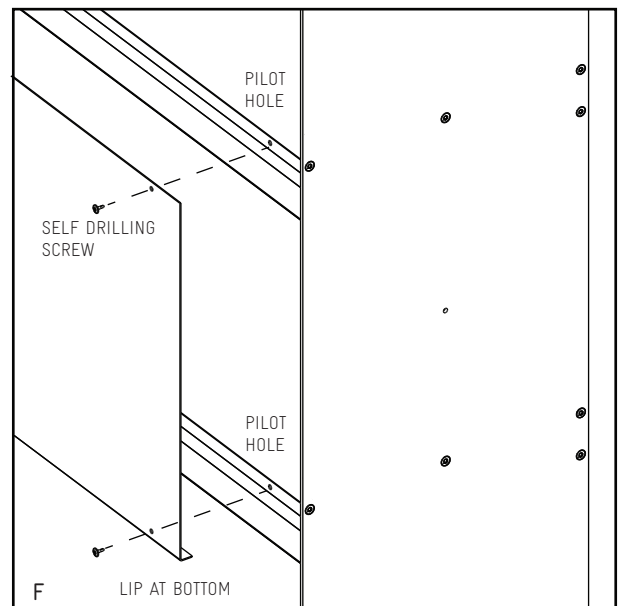

Tall units require two levels of back panels with openings between as shown. The panels add strength and stop any sideways movement. Position the lip of the back panel under the shelf and fix into position using the self drilling screws and screw into the pilot hole locations.

Our JOIN units all come with a Join connector. Use one or two connectors to link your units together to make longer lengths. Units of different heights and widths can still be linked together as shown below.

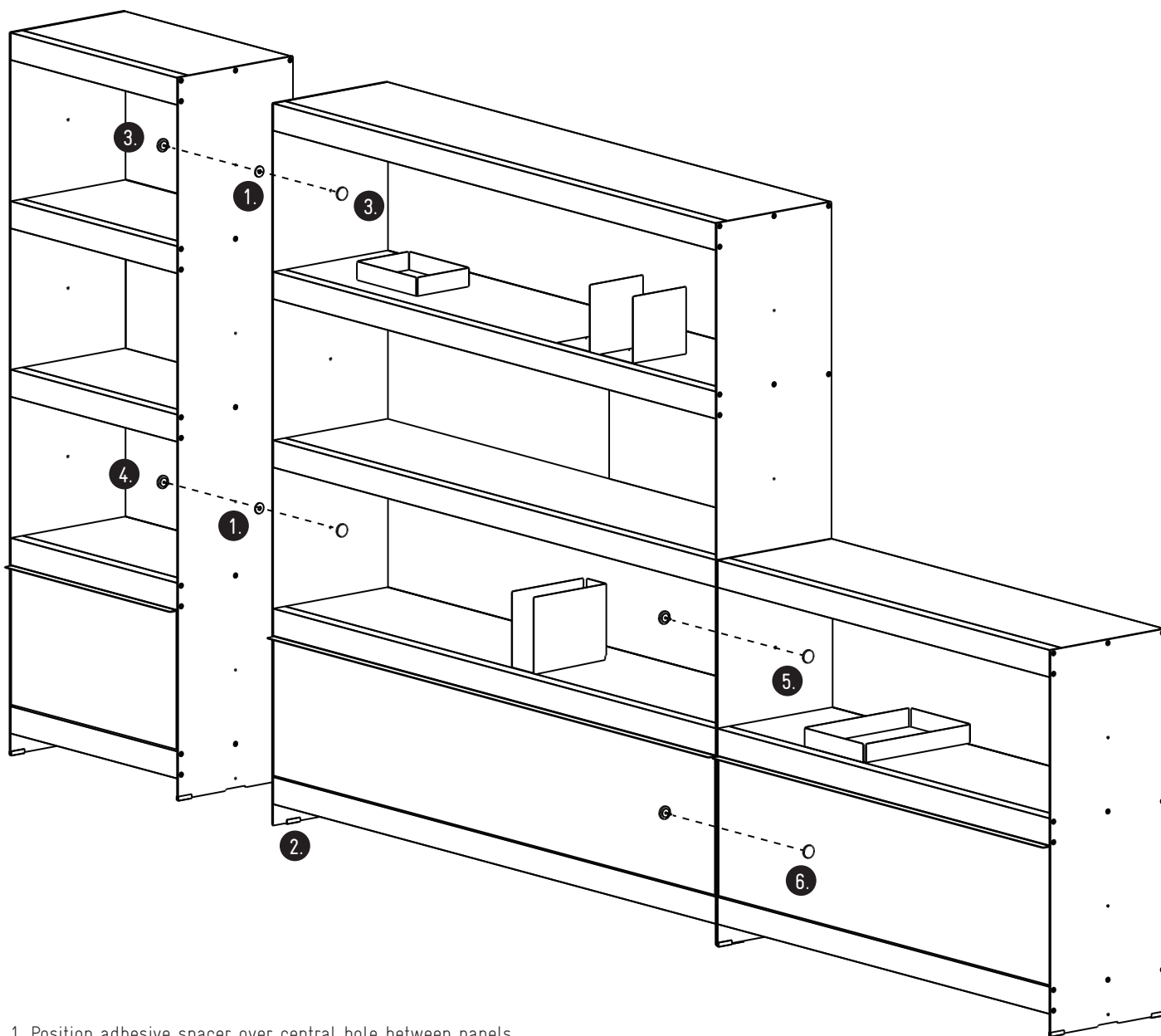

1. Position adhesive spacer over central hole between panels
2. Position/slide feet inwards on one unit
3. Bring units together & screw connectors to secure
4. Repeat at a lower levels
5. Use connectors to join small units
6. Connectors can be added behind the door