

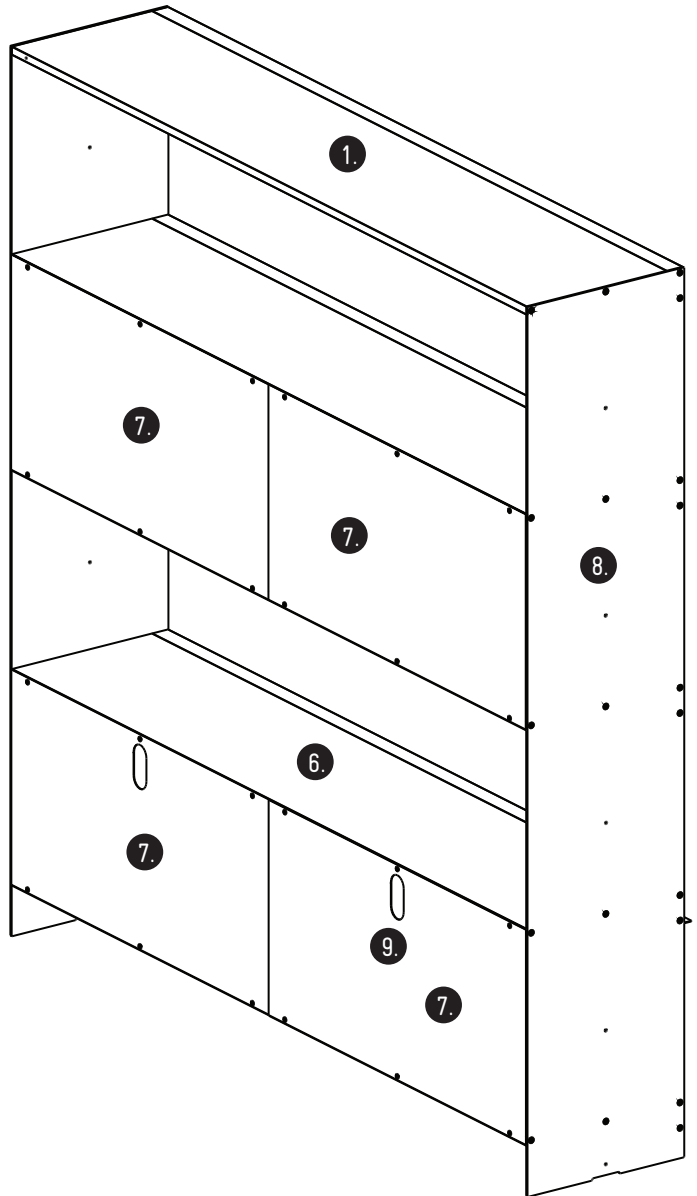

All our JOIN units are assembled the same way. This guide shows the largest being assembled, all the parts are bolted or screwed together. We would recommend using two people to assemble and lift the largest units T4 & T5 up from the floor assembly position.

FRONT VIEW

REAR VIEW

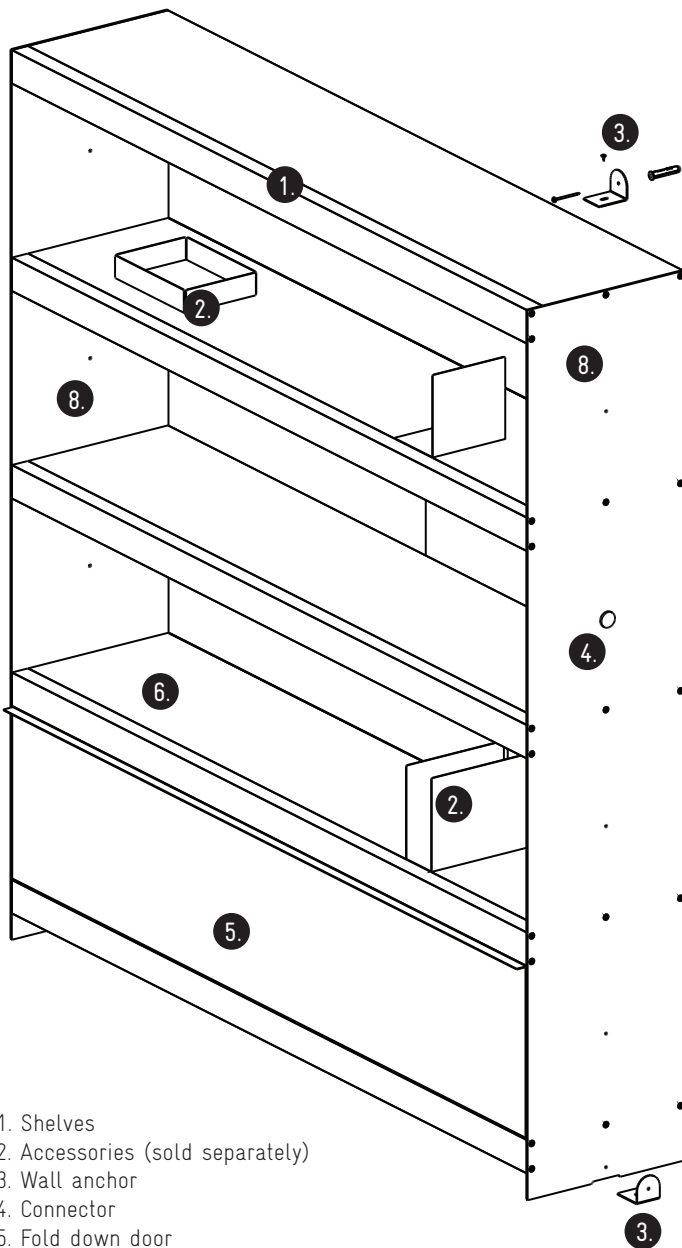

1. Shelves
2. Accessories (sold separately)
3. Wall anchor
4. Connector
5. Fold down door
6. Shelf with closing strip/tab
7. Back panels
8. Side panels
9. Cable opening

Following the steps below but contact us if you need more help, we are always happy to help, you can contact us on (0)1727 834034 or email us at studio@madebyonandon.com. All our JOIN units are assembled the same way. This guide shows the largest being assembled.

1.

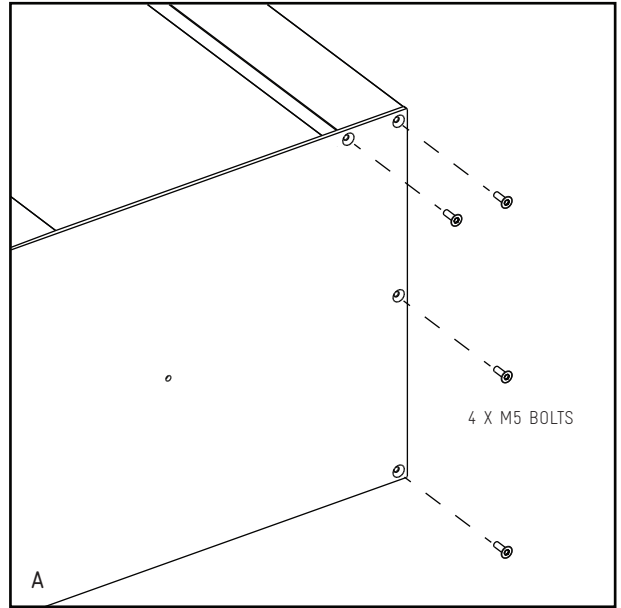
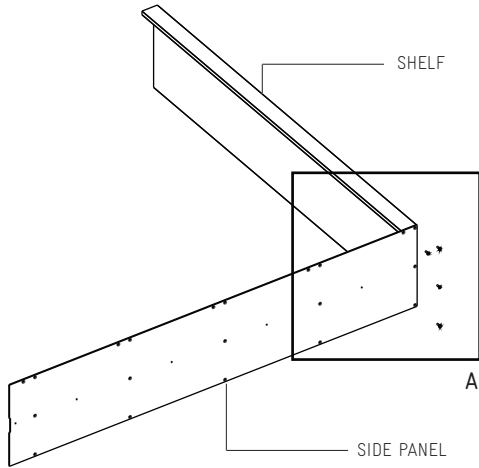

Cover the floor area with a soft surface (blanket or rug). Assemble the unit on the floor facing up so the parts are on their back. Connect the top shelf with the M5 bolts using an electric drill on a medium torque. Use the hex key 3mm to finish it off so you don't overtighten the bolts.

2.

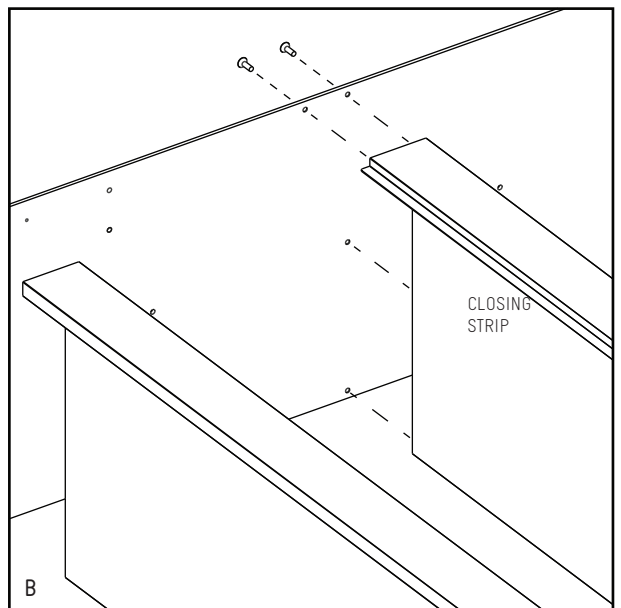
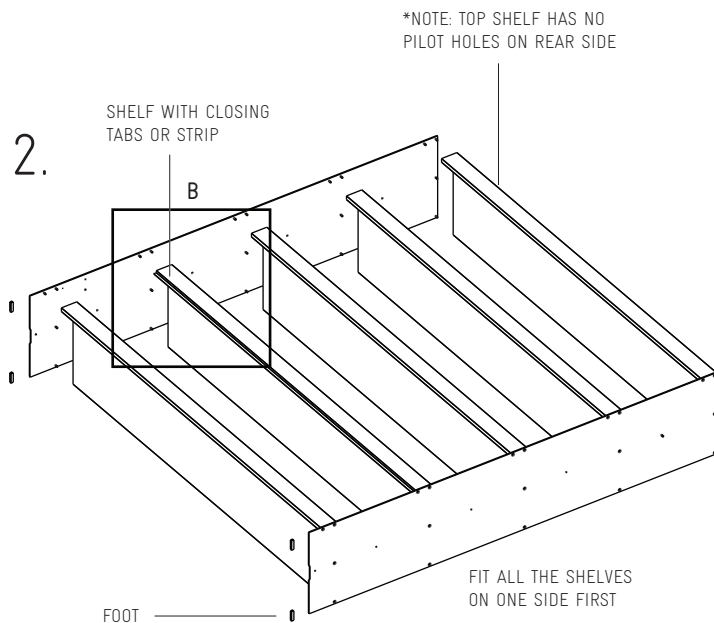

Connect all the shelves to the first side panel before connecting the other side, but fit the shelf with the closing strip two shelves up from the bottom. When both side panels are connected slide or push on the four feet.

Fold down doors are fitted to the bottom of the module by connecting two hinges and two flap stays. Magnets in the top of the door locate with the closing strip or tabs above to keep the door shut. The friction flap stay can be adjusted to control the doors movement and speed of opening.

3.

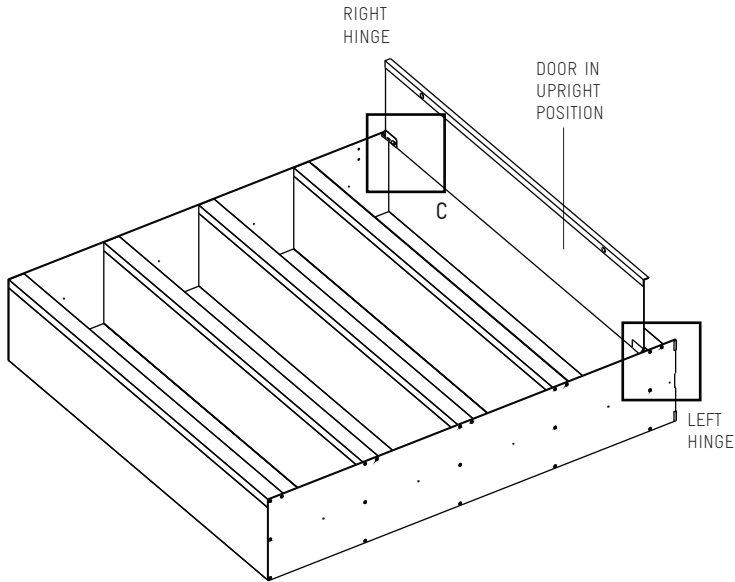

FIT THE HINGE

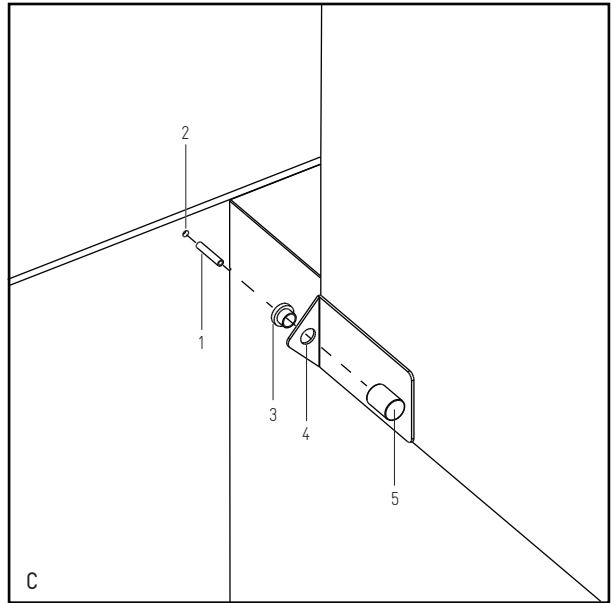

Screw in the socket screw (1) into the side panel hole (2) tighten using the 2.5mm hex key, don't overtighten. Insert the shoulder washer (3) into the pivot hinge hole (4) on both sides of the door. Slide one side of the door onto the socket screw. Hold the door and align the other side, hinge hole and side panel hole and locate the 2nd socket screw through both and screw into the side panel. Tighten with the hex key. Attach the hinge caps (5) to cover the socket screws.

4.

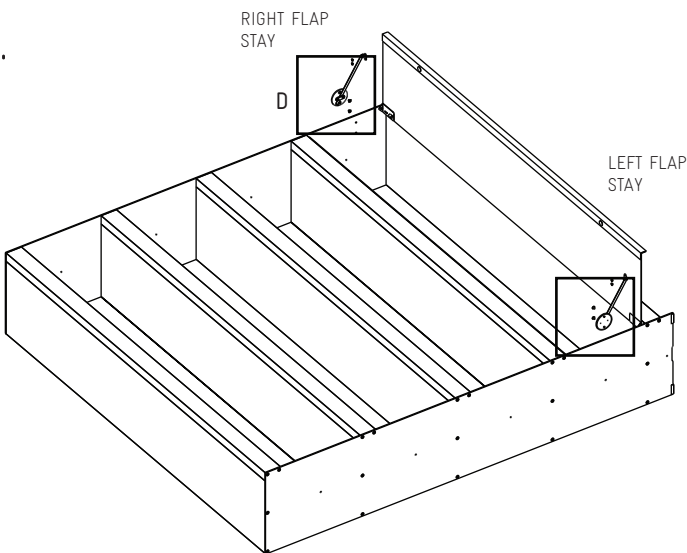

FIT THE FLAP STAYS

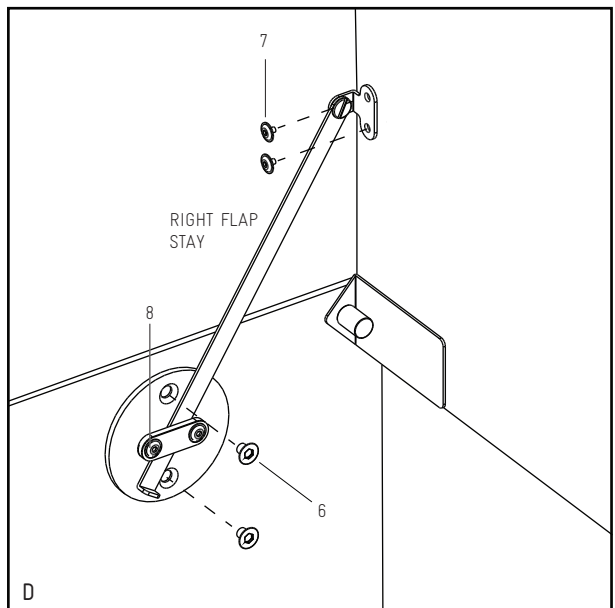

Bolt the right flap stay to the right side panel (6) using the countersunk bolts. Next bolt the flap stay arm to the door using the m4 bolts with the 2.5mm hex key. When completed repeat both steps for the left flap stay. The bolts (8) can be adjusted with very small quarter turns to increase or decrease the friction and control of the door movement.

We would recommend two people lift the largest units T4 & T5 into the upright position. Protect the bottom corners when raising the unit into position. Check your door is working and fitted correctly and then fit your back panels.

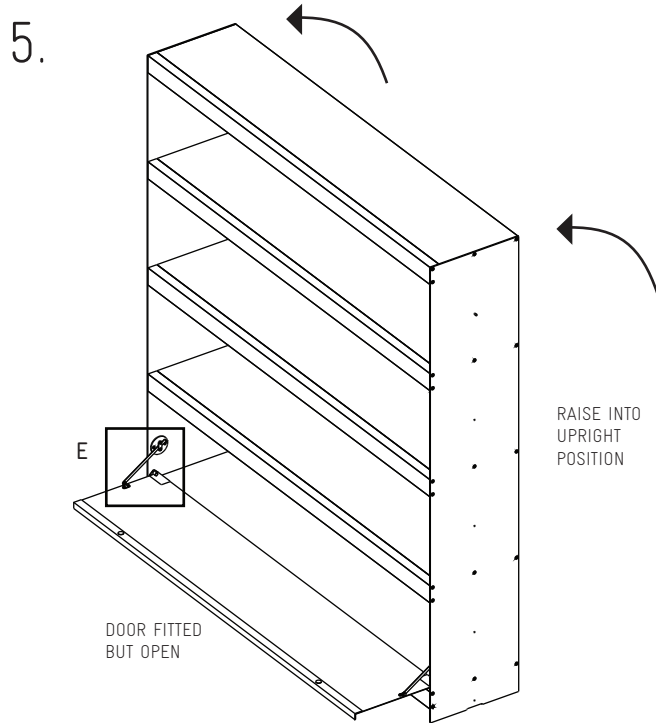

FLAP STAYS FINISHED

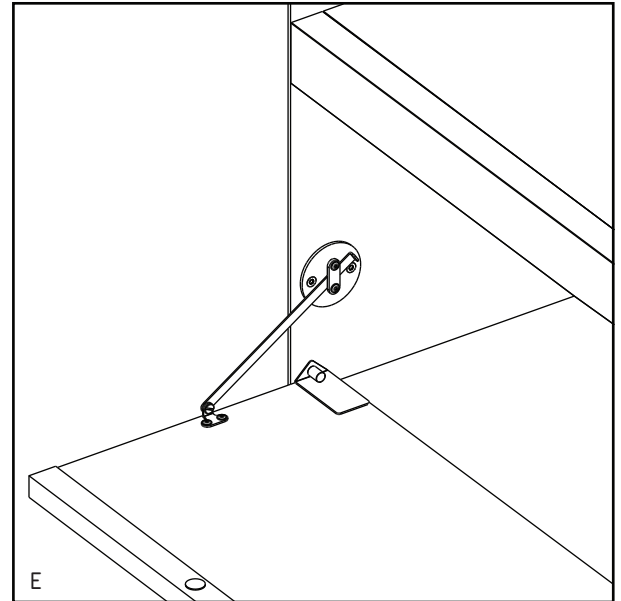

Your door parts should look like this when the unit is in its upright position.

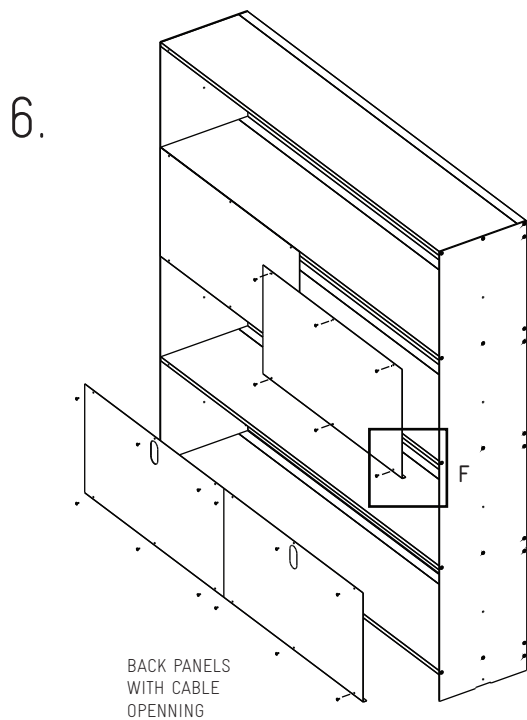

FIT PANELS TO REAR

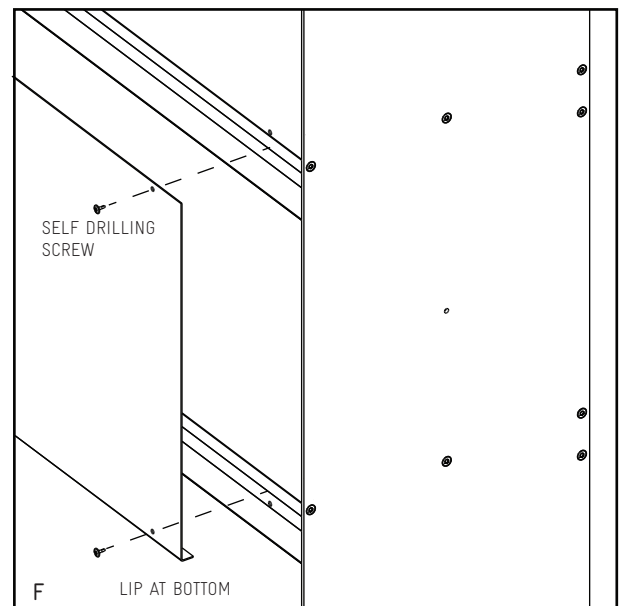

Tall units require two levels of back panels with openings between as shown. The panels add strength and stop any sideways movement. Position the lip of the back panel under the shelf and fix into position using the self drilling screws (electric screwdriver) and screw into the pilot hole locations. Repeat for all your panels.

Our JOIN units all come with a Join connector. Use one or two connectors to link your units together to make longer lengths. Units can be different heights or sizes but can still be linked together as shown below.

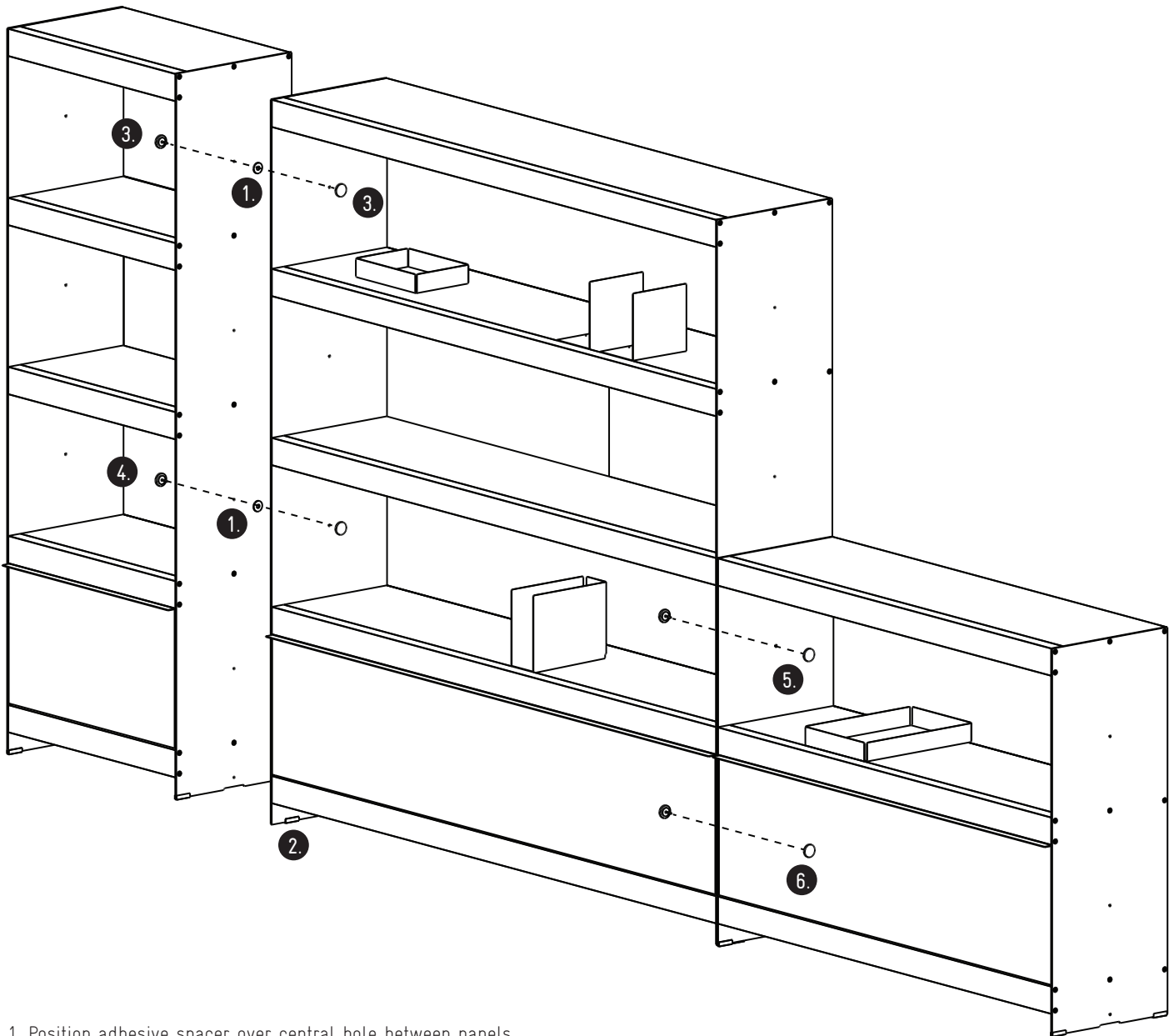

1. Position adhesive spacer over central hole between panels
2. Position/slide feet inwards on one unit
3. Bring units together & screw connectors to secure
4. Repeat at a lower levels
5. Use connectors to join small units
6. Connectors can be added behind the door